

Pressure and vacuum relief Valves with Integrated Arrester

For pressure - vacuum relief and flame control



Emission control and safety equipment, for low pressure storage tanks



# DESCRIPTION

Its main function is to control outbreathing and inbreath of the atmospheric or semi-pressurized storage tanks, getting as the main benefit, the control of emissions into the atmosphere, this generates savings, environmental protection, and tank operational safety.

The day-to-day operation of the storage tanks makes it mandatory to have venting regulation devices, because in absence of such devices, product vapors could be emitted into the atmosphere, which besides leading to excessive spending and waste, it pollutes the air with gasses that may damage health, in addition to represent a fire hazard of the organization.

The design, manufacture and characteristics of the valves meets the guidelines issued by international standards: API 2000 seventh edition, and ISO 28300, concerning standard venting in atmospheric storage tanks.





Likewise local standards conceived to specify, service and test these devices issued by chemical and petrochemical plants are met.

The protection of a storage tank is the combination of a relief valve mounted on a flame arrester, this assembly is called venting equipment.

Series 55A include a deflagration type flame cells for group C and D gas (IIA-II B3), at the air inlet and vapor outlet, which prevents the possible entry of fire or energy that might generate combustion, without limiting the valve's flow capacity.

This arrangement provides a venting equipment for atmospheric tanks in one single component

The flame cell is made of stainless steel 316; it is easily removed from the valve for inspection, cleaning and / or replacement without having to remove the entire body of the valve from the tank.

This enables quick and safe maintenance, without all the complications of disassembly procedures. Saving time and money with less risk

Because the plates are mostly closed in a normal valve operation, the flame elements are not constantly exposed to the product contained in the tank, which prevents premature saturation of the cells and the surface of the element. This extends the period between cleaning process, preventing the risk of overpressure and tank collapse due to a clog in the flame arrester.

The protection to a storage tank combines a relief valve assembled over a flame arrester; this assembly is known as Venting Equipment.

Protectotank series 55A will provide complete protection.

The 55A series is an excellent alternative in tanks containing liquids leaving solid residues because the polymerize process of the vapors or having turbulent filling/ emptying processes that may splash product on the venting equipment. The cell on the vacuum side makes it possible to observe the degree of saturation produced by solid pollutants, such as dust, and thus be able to prevent saturation or clogging by the air coming into the tank due to the suction effect.

The design, manufacture, test and characteristics of the valves with flame arrester included meets the guidelines issued by international standards: API 2000 seventh edition, and ISO 28300 all concerning standard venting in atmospheric storage tanks.

ISO 16852, UL 525 for flame arresters design and testing.

Likewise local standards conceived to specify, service and test these devices issued by chemical and petrochemical plants are met.



# SPECIFICATIONS

## Body materials:

Aluminum, carbon and stainless steel 316.

## Internal Materials:

Pressure trim and vacuum trim stainless steel 316 (plate, support, screws, bolts, nuts, guides and pressure screen).

## Nominal Connection Size:

2", 3", 4", 6", 8", 10" and 12" diameter

## Connections:

ANSI/ ASA flanges 150#, flat face type (FF) for aluminum valves, raised face (RF) for steel valves. (Other options are available).

## Spring Loaded:

Higher than 2.32 oz/sq inch and up to 15 Psi.

## Diaphragm

Floating-type FEP (Teflon).

## Standard Setpoint Weight loaded:

Standard of 1/2 oz/sq inch up to 2.32 oz/sq inch, both in pressure as well as in vacuum.

## Flame Cell:

Made of stainless steel 316 for group C and D gas (IIA-IIIB3) deflagration type, in compliance with UL 525 test for flashback flame.

## Flow Capacity Test:

Certified flow capacity by an accredited flow laboratory issued by the Mexican Accreditation Entity (ema), with international traceability recognition agreement (ILAC), for pressure and for vacuum, in accordance with ISO 28300, API2000 Seventh edition.

## Maximum Leak Rate Test:

Maximum leak rate 1 SCFH; at 90% of set point for all sizes. Exceeds the ISO28300 - API 2000 requirement. All valves will include this test report.

## Coating:

High-solids polyurethane for marine environment meets ISO 12944. Other methods upon request.

## Operation Test:

Pressure and vacuum setpoint test to meet ISO28300 - API 2000 standards. Each valve will include a test report with a graphic chart for pressure / vacuum, and leak rate test.

All testing procedures are made on a certified test bench with an international traceability recognition agreement (ILAC).

## Packing:

Includes protection for international transportation and storage.

## Certification:

Certified ISO 9001:2015 Quality Management System for designing, manufacturing, service and testing by international IQNet.



# Dimensions

Connection Size	Dimension		
	A	B	C
2" (50.8mm)	14 3/4" (374.65mm)	13 1/4" (336.55mm)	12 1/2" (317.5mm)
3" (76.2mm)	16" (406.4mm)	17 1/4" (438.15mm)	12 1/2" (317.5mm)
4" (101.6mm)	22 3/8" (568.32mm)	21 1/4" (539.75mm)	20" (508mm)
6" (152.4mm)	23 1/4" (590.55mm)	25 1/4" (641.35mm)	16 5/8" (422.28mm)
8" (203.2mm)	27 3/4" (704.85mm)	32 1/4" (819.15mm)	20 1/4" (514.35mm)
10" (254mm)	28 1/2" (723.9mm)	36" (914.4mm)	22 1/2" (565.15mm)
12" (304.8mm)	29" (736.6mm)	40 1/2" (1028.7mm)	25" (635mm)

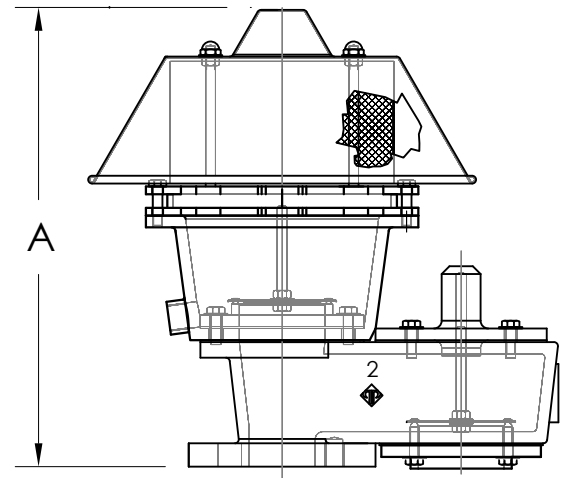
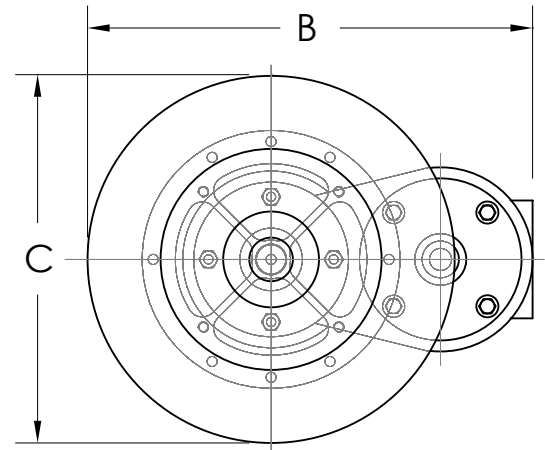

1) Model	
	55A

2) Connection size	
02	2"
03	3"
04	4"
06	6"
08	8"
12	12"

3) Body material	
01	356 type aluminum
05	Carbon steel
09	316 Stainless Steel

4) Internal materials	
09	316 Stainless Steel

# Model Selection

Ordering Example:  
55A-02-01-09-03-00

Refers to a series 55A free vent valve, 2" diameter connection, aluminum body and 316 stainless steel internal parts, Teflon (FEP) diaphragm. Set for ½ ounce per square inch (STD) pressure – vacuum .

5) Diaphragm	
03	Teflon(FEP)

6) Calibration type	
00	Weight loaded setpoint 0.5 (STD) up to 2.3 oz/ inch2
01	Spring loaded for high calibration (Higher than 2.3 oz/sq inch up to 15 PSI)
	Special options



## List of Materials

Quantity	Description
01	1 piece Valve Body
02	*2 pieces Pressure seat gasket
03	1 piece Valve arrester chamber
04	1 piece Valve pressure Seat
05	1 piece Lower support for arrester seat
06	1 piece Pressure arrester element
07	1 piece Upper support for arrester seat
08	4 pieces Hood support bolt
09	1 piece Protection hood
10	*1 piece Vacuum top gasket
11	1 piece Vacuum lid
12	*1 piece Vacuum seat gasket
13	1 piece Vacuum seat
14	1 piece Vacuum arrester element
15	2 pieces Valve plate
16	4 pieces Cap nut for hood
17	8 pieces Flat washer
18	8 pieces Hex bolt 3/8
19	6 pieces 5/16 screw x 1-1/2
20	8 pieces Hex bolt 3/8
21	6 pieces Hex bolt 3/8 ø x 1-1/2
22	1 piece Drain
23	2 pieces Guide pin for plate
24	*2 pieces Valve diaphragm
25	2 pieces Plate support
26	4 pieces Hex nut for plate
27	4 pieces Flat washer for plate
28	1 piece ID plate
29	2 pieces Pop rivet

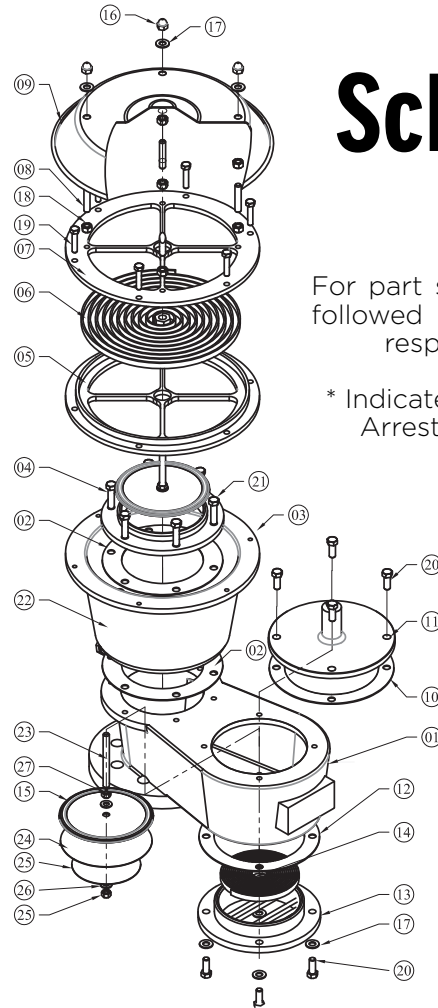

# Schematic view

For part selection, indicate model followed by a diagonal plus the respective part number.

\* Indicates parts from service kit.  
Arrester flame cell available

# Additional value for maximum control emissions

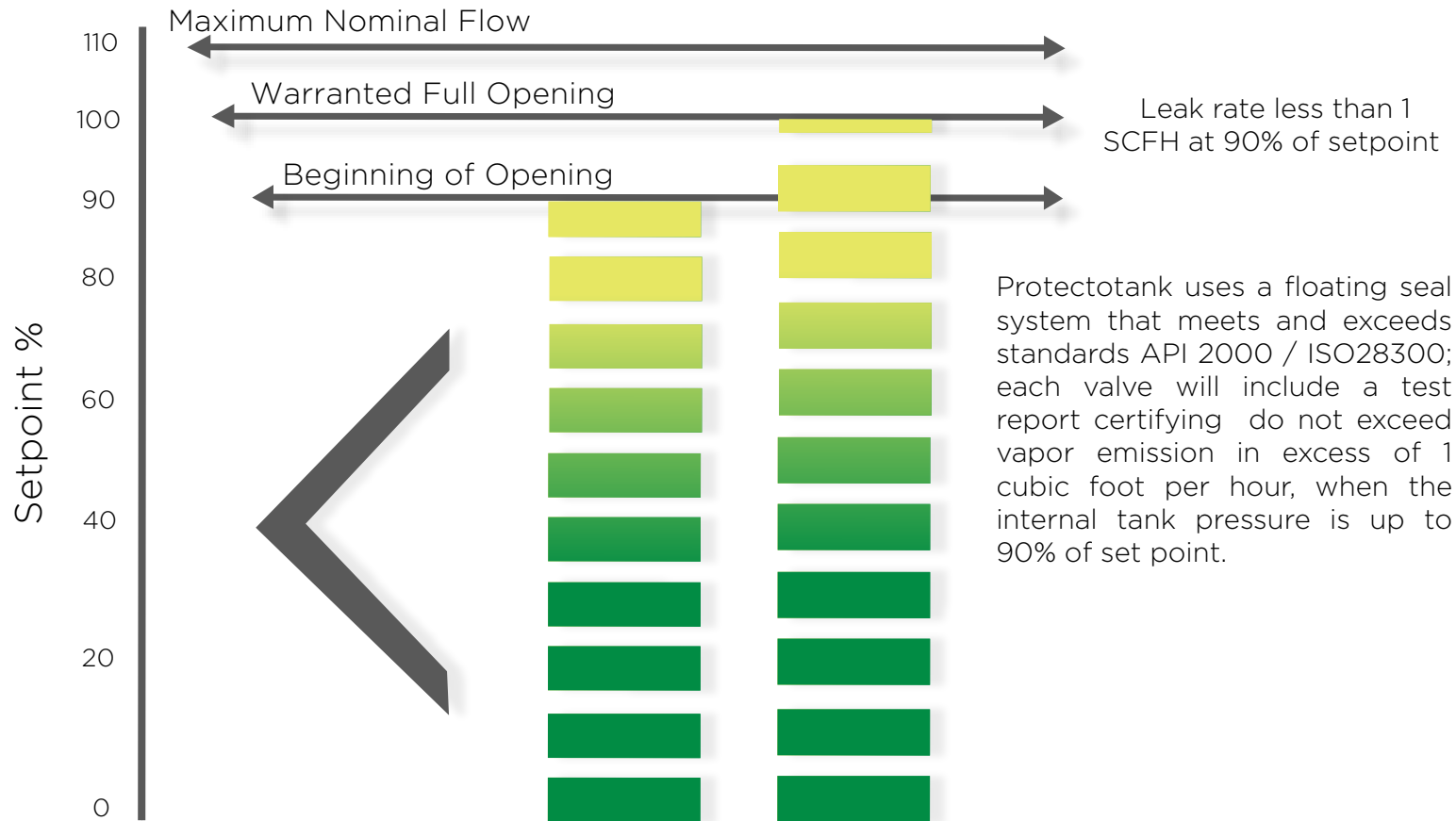

# Environmental emissions control

Protectotank make possible savings in vapor emissions into the atmosphere which cause pollution and increase risks; this contributes into economical saving, increased safety in the operation of the tanks and reduces fire hazards.

The benefits and purpose of a venting equipment are:

## **Protection:**

Against overpressure and overvacuum in the tank

## **Control:**

Eliminate Free vapor exhaust.

## **Protection to the contained liquid:**

The tank remains closed most of the time.

## **Financial Benefit:**

Prevents constant product losses by evaporation.

## **Safety:**

The permanent existence of a highly flammable vapor cloud.

## **Environment:**

Stops the continuous emission of vapors to the atmosphere.





Our facilities meets ISO 17025 international standard "General requirements for the competence of testing and calibration laboratories" our test laboratories have been accredited by the Mexican accreditation entity (ema) for low pressure and vacuum valves pressure and flow testing , all valves we produce include a test report with legal validity through international traceability recognition agreement (ILAC).

# ACCREDITED TEST LABORATORY



## Maintenance, refurbish and adjustment services

Protectotank offer maintenance, refurbish and adjustment services through our rep network. there are also available service kits and technical support directly form factory.



# Experience additional value

Protectotank have been in the market for over 25 years maintaining a constant innovation attitude, that continuously applies improvements to the products. Protectotank began to export in 2001 having customers in all America and some other countries around the world.

The facilities include the best in class CNC machinery and automated systems, accredited test benches and certified quality systems to meet the most demanding standards and all the customer requirements.

The engineering department may offer you a customized solution for all your applications with an affordable price and delivery time.



# Certifications



Clean Industry



SIGE



IQ Net



Central Laboratory



Mobile Laboratory



Lesser



# Product warranty

Protectotank warrants that products that are manufactured by Seller are manufactured in accordance with published specifications and free from defects in materials and / or workmanship for a period of (12) twelve months. Seller, at its option, will repair or replace any products returned intact to the factory, transportation charges prepaid, which Seller, upon inspection, could determine to be defective in material and / or workmanship. The foregoing shall constitute the sole remedy for any breach of Seller's warranty.

Protectotank shall be solely responsible for the design, development, supply, production, and performance of its products hereunder, and the protection of its trade name or names, if any. It assumes no responsibility, for products modified or changed by its agent or customer, or any other third party. Any such modifications or changes to products sold by Seller hereunder shall make the product limited warranty null and void.





Prolongación Industria Textil No. 13,  
Col. Parque Industrial Naucalpan, Naucalpan  
Estado de Mexico 5348  
Phone: 52 55 53 01 12 95

